



Texas Electronics, Inc.

The Gold Standard in Weather Instrumentation Since 1957



WIND, LIGHT INDUSTRIAL USER'S MANUAL

TEXAS ELECTRONICS, INC.

5529 Redfield St. Dallas, TX 75235

P.O. Box 7225 Dallas, TX 75209

Phone (214) 631-2490

Fax (214) 631-4218

Toll Free (800) 424-5651

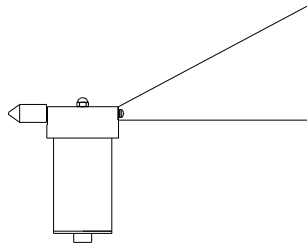

MODEL TD-4 WIND DIRECTION SENSOR

DESCRIPTION

The Texas Electronics, Inc. TD-4 Wind Direction Sensor is a mechanical style wind meter that measures the horizontal wind azimuth. This unit combines small physical size with superior bearings to meet the EPA's Prevention of Significant Deterioration (PSD) starting threshold requirements.

The TD-4 wind direction sensor is a freestanding device for measuring the direction of wind. The sensor consists of a vane and counterweight assembly, which is mechanically coupled to a potentiometer (variable resistor). As the vane rotates in the wind, the potentiometer changes resistance proportionally to the direction of wind.

SPECIFICATIONS

Operating Range:	0-360° mechanical
Signal Presentation:	5000 ohm potentiometer, 10000 ohm potentiometer, or Analog 4-20 mA
5000 ohm output:	0-355° electrical range 3 VDC excitation minimum
10000 ohm output:	0-357° electrical range 3 VDC excitation minimum
Analog 4-20 mA output:	0-355° electrical range 10-30 VDC
Performance:	
Accuracy:	+/- 3.0°
Starting Threshold:	0.6 mph (0.27 m/s)
Resolution:	1°
Potentiometer Linearity:	+/- 1.0%
Environmental:	
Operational Envelope:	0-135 mph (0 to 60 m/s)
Temperature:	-40 to 160° F (-40 to 70° C)
Relative Humidity:	0-100%
Physical:	
Vane Overall Length:	8.5" (21.6 cm)
Overall Height:	6.75" (17.2 cm)
Turning Radius:	13" (33 cm)
Weight:	0.5 lbs (0.23 kg) less cable
Bearings:	APEC 3 or better
Mounting Base:	Screw attachment, 10-32 machine screw
Cable:	60' (18.3 m) 3 conductor 22 gauge
Warranty:	3 year

FEATURES & BENEFITS

- Superior low starting threshold
- Long life hybrid dual wiper potentiometer
- No plastic parts for extremely long life
- Precision stainless steel bearings for stability and repeatability
- Crossarm included with purchase of matching wind speed sensor
- Easy installation and maintenance
- Over 25 years in production
- Lightweight and rugged anodized aluminum exterior

INSTALLATION & MAINTENANCE

Installation consists of threading the 10-32 mounting base into our crossarm or any other suitable beam. If a crossarm is used, the entire unit can be bolted to a mast or attached via U-bolts.

The sensor is dynamically calibrated at the factory and due to the nature of its operation should not require field calibration. Calibration is a matter of proper orientation during installation. A magnetic compass is recommended for proper orientation. Field maintenance should include occasional cleaning of the vane assembly and inspection of the internal mechanism to make sure it is free from insects and debris. In some applications users may need to occasionally verify and document sensor accuracy with a calibration dial/vane. Possible bearing and potentiometer replacement every three to five years to maintain low starting threshold.

ORDERING INFORMATION

<u>Model #</u>	<u>Description</u>
TD-4	Wind Direction Sensor, Light Industrial
TD-410	Wind Direction Sensor, Light, 10K
TD-4A	Wind Direction Sensor, Light, 4-20 mA

* Sensor is designed to work with TV-4 series wind speed sensors.

Optional Parts / Accessories

Cable	Additional Cable
-------	------------------

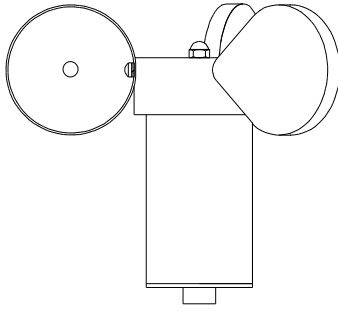

MODEL TV-4 WIND SPEED SENSOR

DESCRIPTION

The Texas Electronics, Inc. TV-4 Wind Speed Sensor is a mechanical style anemometer that measures the horizontal velocity of wind. This unit combines small physical size with superior bearings to meet the EPA's Prevention of Significant Deterioration (PSD) starting threshold requirements.

The TV-4 wind speed sensor is a freestanding device for measuring air velocity. The sensor consists of a lightweight 3-cup anemometer, which electromechanically converts wind speed into a measurable electronic signal.

The output signal can be presented in 3 optional forms: a pulsed DC signal, an AC frequency, or a conditioned analog signal. Each output has a specific application. The pulsed DC signal is used where high-accuracy is needed and continuous power is not a problem. The AC frequency output is used in situations where power consumption is critical. And finally, the conditioned analog signal is used to easily and quickly communicate with virtually all digital control systems such as PLC's or SCADA systems.

SPECIFICATIONS

Operating Range:	0-100 mph		
Signal Presentation:	Pulsed DC output - light chopper AC Frequency, or Analog, 4-20 mA (Please specify)		
Pulsed DC output:	20-slot disc 1 MPH = 520 pulses/min. 100 MPH = 52000 pulses/min.	Input Power:	+5.0 VDC @ 5mA (typical) (Other voltages available upon request)
AC Frequency output:	26 mV/MPH (typical) 0.133 Hz/MPH	Input Power:	None (self-generating)
Analog 4-20 mA out:	4 mA = 0 MPH 20 mA = 100 MPH	Input Power:	10-36 VDC
Performance:			
Accuracy:	+/- 2.0 mph (0.89 m/s)		
Distance Constant:	> 21.7' (6.6 m)		
Starting Threshold:	0.6 mph (0.27 m/s)		
Environmental:			
Operational Envelope:	0-135 mph (0 to 60 m/s)		
Temperature:	-40 to 160° F (-40 to 70° C)		
Relative Humidity:	0-100%		

Physical:

Cup Wheel Diameter:	6.0" (15.3 cm)
Overall Height:	4.75" (12.1 cm)
Turning Radius:	3.0" (7.6 cm)
Cup Diameter:	2.0" (5.1 cm)
Bearings:	APEC 3 or better
Mounting Base:	Screw attachment, 10-32 machine screw
Weight:	0.5 lbs (0.23 kg) less cable
Cable:	60' (18.3 m) 3 conductor 22 gauge

Warranty: 3 year

FEATURES & BENEFITS

- Superior low starting threshold due to small physical size
- No plastic parts for extremely long life
- Precision stainless steel bearings for stability and repeatability
- Crossarm included with purchase of matching wind direction sensor
- Easy installation and maintenance
- Over 5 years in production
- Lightweight and rugged anodized aluminum exterior

INSTALLATION & MAINTENANCE

Installation consists of threading the 10-32 mounting base into our crossarm or any other suitable beam. If a crossarm is used, the entire unit can be bolted to a mast or attached via U-bolts.

The sensor is dynamically calibrated at the factory and due to the nature of its operation should not require field calibration. Field maintenance should include occasional cleaning of the cup assembly and inspection of the internal mechanism to make sure it is free from insects and debris. In some applications users may need to occasionally verify and document sensor accuracy with a synchronous test motor. Other possible routine maintenance is to replace the bearing housing assembly every three to five years to maintain low starting threshold.

ORDERING INFORMATION

<u>Model #</u>	<u>Description</u>
TV-4	Wind Speed Sensor, Light Industrial (Specify supply voltages other than 5 VDC)
TV-4AC	Wind Speed Sensor, AC Generator
TV-4A	Wind Speed Sensor, Analog 4-20 mA

*Sensor is designed to work with TD-4 wind direction sensor.

Optional Parts / Accessories

Cable Additional Cable

PROPER EXPOSURE OF METEOROLOGICAL INSTRUMENTS

Generally recognized guidelines follow which depict "ideal" sensor mounting locations. These guidelines or "rules of thumb" are only suggestive in nature in an attempt to aid the user to selecting optimum representative sampling locations for a particular sensor.

Reference was made to US Weather Bureau Installation criteria in preparing this data (See Reference 1).

WIND EQUIPMENT:

So far as available sites permit, wind sensors should be placed above the ground on a freely-exposed tower (20 feet or higher) and over terrain that is relatively level and free from obstructions to wind flow. When a compromise must be made, sensing units should be exposed at least 12 feet above any obstruction within 100 feet and at least as high as any obstruction within 100 to 200 feet of the wind equipment. Support towers or masts should not be of such bulk or shape as to create an appreciable obstruction to wind flow. Avoid sites where local obstructions may create up-or-down drafts, eddy currents or jet-flow effects. When sensors are roof-mounted, they should be installed at least 10 feet (or greater) from the roof surface depending upon the particular installation site. Turbulence and other local effects can be reduced somewhat by mounting sensors on the upwind and of the building (that end of the building exposed to the most common local prevailing winds). Horizontal-mount booms which extend from existing towers should be fabricated so that sensors will extend a distance of 5 to 10 feet from the tower assembly (dependent on tower thickness).

Wind direction sensors are oriented upon installation in reference to either true north or magnetic north. True north is obtained by applying a local magnetic variation correction factor to a magnetic north compass indication (magnetic variation for a particular locality is obtainable from the nearest Weather Bureau Branch Office). Indicator readings for a true north sensor orientation will then be in terms of true geographic compass points. All U.S. Weather Bureau surface wind data used for observational network reporting purposes and general public use is given in reference to this true north format. Indicator readings for a magnetic north sensor orientation will be in terms of actual readings as would be obtained from directly viewing a magnetic compass instrument. Wind direction data at Federal Aviation Agency and other aircraft reporting facilities (for direct control tower-to-pilot utilization) is always made in reference to this magnetic north format.

REMOTE TEMPERATURE/HUMIDITY SENSORS AND INSTRUMENT SHELTERS:

Whenever possible, instrument shelters* as well as remote temperature and/or humidity sensors should be installed at a height of 4 feet (or greater) over earth or sod at least 100 feet from any concrete or other hard-surfaced area and not closer to any other object than four times the height of the object above the instrument shelter or remote sensors. Avoid roof installations if possible. If it is necessary to roof-mount shelters and sensors, they should not be closer than 30 feet to any large, vertical reflecting surface (walls, etc.), exhaust fans, or cooling towers. Electronic remote sensors when roof-mounted should be at least 9 feet (or greater) above the roof surface. To minimize radiation effects from the roof, they can also be mounted on a horizontal boom so that they will extend from the side of a building roof or existing tower. Horizontal booms should extend approximately 5 to 10 feet from the side of the building roof or tower assembly.

PRECIPITATION GAUGES:

Rain gauges should be installed on a level plot of ground, at a distance from any object of at least two and preferably four times the height of the object above the top of the gauge. All types of gauges must be exposed with the rim of the receiver in a horizontal plane and at a level well above the average level of snow surfaces.

* Standard U.S. Weather Bureau cotton-region shelter (Spec. No. 450.0615, Rev. 8/67)

Roof-mounting of rain gauges should be avoided when possible. Air currents at heights other than at ground level have been observed to cause an apparent decrease in rainfall catch commensurate with the increase in mounting height above ground level.

Objects which individually or in small groups constitute a "windbreak" reduce prevailing wind speed in the vicinity of the gauge. This reduction of wind speed will, as a consequence, also reduce possible eddy currents and turbulence around the gauge. The presence of such objects is usually beneficial in providing a more accurate rainfall catch. Ideally, the "windbreak" objects (fences, bushes, etc.) should be generally uniform in height and distance from the gauge. Height above the gauge should not exceed about twice their distance from the gauge.

ANEROID BAROMETERS - SELF-CONTAINED MECHANICAL INSTRUMENTS AND ELECTRONIC REMOTE BAROMETRIC PRESSURE SENSORS:

Select a site where the instrument will not be subject to rapid fluctuations of temperature or to jarring and continuous vibration. Avoid exposing the instrument to direct sunlight or radiant heaters and to direct drafts such as open windows and doors.

Reference 1:

U.S. Department of Commerce - National Weather Service Bulletin
LS 5927 Revised, 0-4.12, January, 1963.

SOLAR RADIATION SENSORS:

The Solar Radiation Sensor is normally mounted on a level surface totally remote from trees, poles, or power lines that might cast a shadow on the sensor at any time of the day. However, there may be occasions, because of extreme latitudes, when it is desired to mount the sensor at some angle other than level.

The sensors may also be mounted on a sun tracking mechanism or behind a shadow band if diffuse sky radiation is to be measured.

WIND DIRECTION & SPEED SENSORS INSTALLATION

These instructions apply to roof-top installation. We advise that you first read over these instructions before beginning assembly as several referenced items are not supplied with your weather equipment (this is because most every installation is unique thus these parts are best obtained by the installer). Reference to the "U-Tube Cross-Bar Installation" figure and ".Sensor Installation" figure may be helpful.

Step 1: Attach the three anemometer cups to the speed sensor head.

Loosen the three set screws on the top of the anemometer (lower unit).

Insert the anemometer cup arms into the holes. Be sure to press the arms all the way in and make sure that the flat areas on the arms face toward the set screws.

Tighten the set screws.

Step 2: Attach wind vane and counter-weight to the direction sensor head.

Loosen the two set screws on the top of the wind vane (upper unit).

Insert the vane and counter-weight into the holes. Be sure to press both parts all the way in and make sure the flat areas on each arm face the set-screws.

Tighten the set screws.

Note: For optimum performance and maximum bearing longevity you may wish to fine-tune the balance of both wind sensors. Place the U-tube flat on a table such that the sensors hang over the edge. Rotate the vane and the cup in 10 degree increments. After positioning the vane and cups verify that there is no movement after releasing your hold (this must be done in a wind-free environment). Balance adjustments are made by loosening the set screw to the lighter cup, counter-weight or fin and shifting it slightly away from the sensor head.

Step 3: Attach cross-bar to U-tube.

Spread end clamps and slide over the U-tube.

Insert cross-bar into the ends of both clamps.

Fasten cross-bar in a level position with screws, nuts and washers.

Step 4: Attach U-bolts to cross-bar and U-tube.

Remove the two nuts and reinforcing plate from both U-bolts (do not remove the toothed bracket).

Insert one U-bolt through the two holes in the cross-bar and the other through the two holes in the bottom of the U-arm (be careful not to damage the wires inside the U-arm).

Replace the tube reinforcing plate on the U-bolt and replace the U-bolt nuts.

Step 5: Slip the U-bolts over the mast and tighten.

Make certain that the anemometer cups do not hit the mast.

Step 6: Attach guy wire clamp just below the U-tube assembly.

Step 7: Attach base mount to the roof or side wall.

Note that the base mount U-bolt will rotate to fit any angle.

Step 8: Install guy wire anchors (not included) or locate secure points for guy wire attachment.

Step 9: Erect mast and install guy wires (not included) and turn-buckles (not-included).

Step 10: Ground the mast to help protect the sensors and structure from lightning hits.

Supplies needed: mast wire clamp, grounding wire, wire supports and grounding rod.

Step 11: Run the sensor wire inside to the console.

Lead in wire is permanently attached to the sensor unit.

Attach to console according to wire color code.

If necessary the cable may be cut down in length or wire may be added with negligible effect on the calibration. If changing cable lengths more than a few hundred feet you may wish contact the factory to determine the severity of the effect on calibration.

Additional cable lengths are available from Texas Electronics if needed.

Step 12: Calibrate the Wind Vane.

Be sure console is operating properly first.

This is normally a two man job with one individual watching the direction indicated by the weather station and the other adjusting the sensor while watching a compass.

Two methods of aligning the vane are available. The first method involves loosening the large set screw at the bottom of the wind direction sensor so that it will rotate on the U-arm. Turn the bottom half of the sensor until the compass readings and the indication match then retighten the set screw. The second method involves rotating the entire mast assembly until proper orientation is achieved; this technique is usually easier because of the heights involved but will usually necessitate repositioning (rotating) of the guy-wire clamp.

If winds are creating rapid fluctuations in the vane making calibration difficult, the vane can be temporarily secured in a fixed position by carefully wedging a thickly folded piece of paper or cardboard into the gap between the upper and lower halves of the direction sensor. An alternative technique is to lap a string over the vane and carefully hold it in position (be careful not to bend the vane when using this approach).

Warranty

Texas Electronics, Inc. (hereafter TEI) warrants the equipment manufactured by it to be free from defects in material and workmanship. Upon return, transportation charges prepaid to TEI, within three (3) years of original shipment of sensors and one (1) year of original shipment of electronics, recorders and indicators, TEI will repair or replace, at its option, any equipment which it determines to contain defective material or workmanship, and will return said equipment to purchaser, F.O.B., TEI. Texas Electronics shall not be obligated however to repair or replace equipment which has been repaired by others, abused, improperly installed, altered or otherwise misused or damaged in any way. TEI will not be responsible for any dismantling, re-assembly, or reinstallation charges.

This warranty is in lieu of all other warranties, expressed or implied. TEI shall not be liable for any special, indirect, incidental or consequential damages claimed in connection with any rescission of this agreement by purchaser.

For a list of specific items covered by the extended warranty, see the *Three-Year Warranty Equipment List*.

Three-Year Warranty Equipment List

Effective February 1, 1992 all of Texas Electronics, Inc. sensors will carry a Three-Year warranty instead of the previous One-Year. The remainder of terms and conditions of the warranty remains unchanged. A specific list of items follows.

Sensors Covered by Three-Year Warranty

Parameter	Model No.
Wind Direction	TD-105 (Synchro) TD-104D (Potentiometer) TD-110-L2 (Photo-Chopper) TD-106 (Potentiometer)
Wind Speed	TV-110-L2 (Photo-Chopper) TV-110-L3 (Photo-Chopper) TV-114 (A.C. Generator)
Barometric Pressure	TB-2012
Relative Humidity	TH-2013 TH-2013V
Rainfall	TR-525 TR-6118
Temperature	TT-101 (Outdoor) TT-103R (Surface Mount) TT-103R-W (Water Probe) TT-309I (Indoor)
Solar Radiation	TS-100

Systems Covered by Three-Year Warranty

Model No.	Description
WSC-5-S	Wind Speed Controller Single Set Point
WSC-5-ST	Wind Speed Controller Single Set Point with Time Delay
WSC-5-D	Wind Speed Controller Dual Set Point
WSC-5-DT	Wind Speed Controller Dual Set Point with Time Delay
WDC-2	Wind Direction Controller